

Swivel

10MB, 15MB, 25MB, 35MB, 50MB

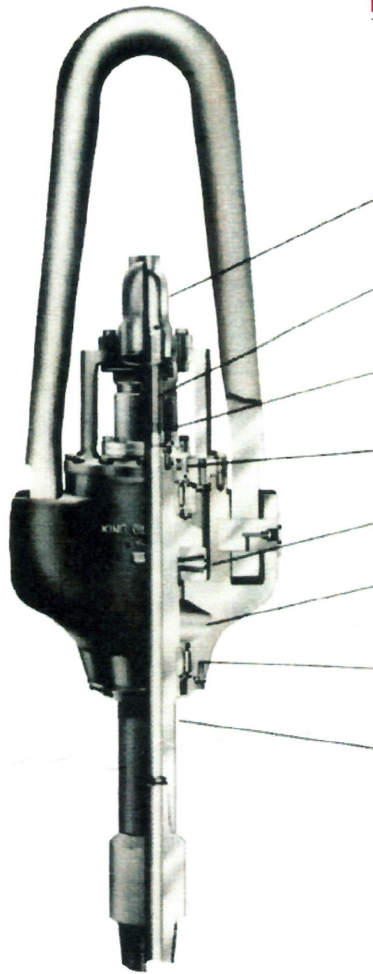

GOOSENECK

Large watercourse and heavy walled for smooth flow and longevity.

WASHPIPE

Hardened and ground finished; "floating" to assure alignment with packing.

QUICK CHANGE PACKAGE

Replaceable cartridge without removing gooseneck.

SEAL

Double-acting upper and lower seal.

MAIN BEARING

Large tapered roller sized to API spec.

LUBRICATION

Large oil cavity and design assures all bearings are flooded with cool oil.

ALIGNMENT BEARINGS

Upper and lower straight roller widely spaced to insure stem alignment.

STEM

Forged, alloy steel for long life, extra long for re-threading.

Model	10MB	15MB	25MB	35MB	50MB
Static Capacity	120 Tons	150 Tons	300 Tons	400 Tons	550 Tons
Rotating Capacity 100 R.P.M. API	78 Tons	97 Tons	193 Tons	258 Tons	367 Tons
Working Pressure (P.S.I.)	5,000	5,000	5,000	5,000	5,000
Bail Diameter at Bend	4 1/4"	5"	5 3/4"	6 3/4"	7 1/2"
Bail Radius for Hook	4"	4 1/2"	4 1/2"	4 1/2"	4 1/2"
Hook Clearance	17 1/2"	20 1/16"	24"	24"	26"
Fluid Passage	3"	3"	3"	3"	3"
Gooseneck Connection	3" Female	4" Female	4" Female	4" Female	4" Female
Spindle Thread Connection	4 1/2" EUE 8 RD	4 1/2" API FH	5 1/2" API Reg.	6 5/8" API Reg.	6 5/8" API Reg.
Saver Sub Thread	4 1/2" API Reg.	6 5/8" API Reg.	6 5/8" API Reg.	6 5/8" API Reg.	6 5/8" API Reg.
Washpipe Packing	Pressure Seal Lip Type	Pressure Seal Lip Type	Pressure Seal Lip Type	Pressure Seal Lip Type	Pressure Seal Lip Type
Uphrust Bearing	Ball	Ball	Ball	Ball	Ball
Main Bearing	Tapered Roller	Tapered Roller	Tapered Roller	Tapered Roller	Tapered Roller
Alignment Bearings	Straight Roller	Straight Roller	Straight Roller	Straight Roller	Straight Roller
Oil Capacity	2.5 gal.	4.5 gal.	7 gal.	10 gal.	11 gal.
Width	20"	26"	30 1/2"	35"	40 3/4"
Length Less Sub	69 1/2"	64 7/8"	93"	97 5/16"	103 11/16"
Weight Less Oil	1,950 lbs.	2,750 lbs.	3,960 lbs.	4,500 lbs.	5,900 lbs.

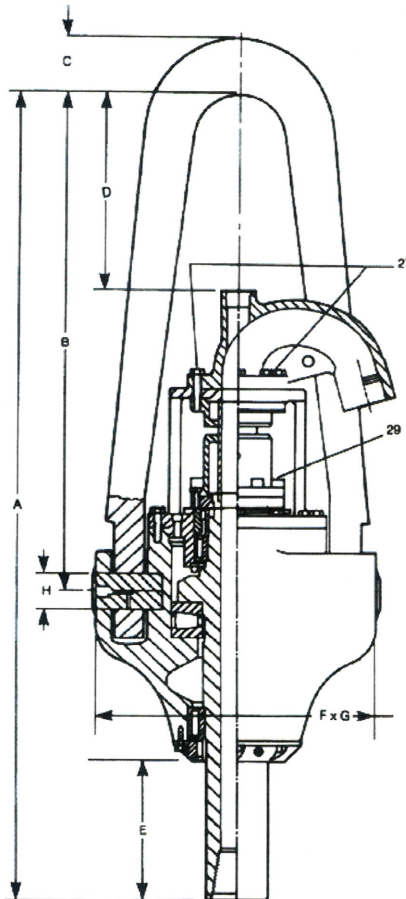
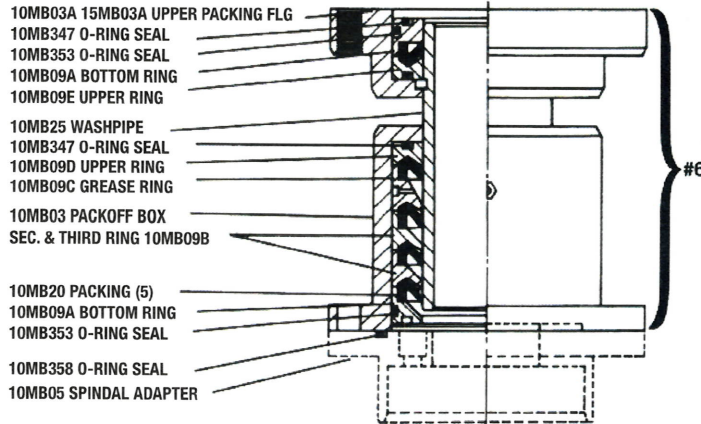

MB Swivel Packing Instructions' Removal

1. Bring swivel down to a safe working height, stop rotation and mud circulation.
2. Unscrew and remove the four (4) bolts, item #27. These are the bolts on the bail side of the bonnet.
3. Unscrew and remove the six (6) bolts, item #29.
4. Collapse packing assembly by prying the upper packing flange down, MB03A of packing box drawing.
5. Remove packing assembly, item #6.
6. Install new O-Ring, item #24.
7. Install new or refurbished packing assembly, item #6.
8. Install the four (4) bolts, item #27 and tighten equally and in opposing directions. ALWAYS TIGHTEN FIRST.
9. Pry the bottom half of the packing assembly down. Install and tighten the six (6) bolts, item #29.
10. Grease the packing through the jerk fitting of the MB03 packing box.
11. Close kelly cock and pressure test to 5,000 P.S.I. or less. Note: A pressure of greater than 1,000 P.S.I. is required to seat the single piece of packing in the upper packing flange. If this is not done, a leak could be present in the area of the upper packing flange.
12. If no leaks are present, begin drilling.

To Refurbish a Removed Packing Assembly

1. Disassemble the old packing assembly and clean all removed metal parts.
2. Inspect and replace all metal parts that are damaged and/or show excessive wear.
3. Install one piece of 10MB20 packing into the bottom ring, 10MB09A.
4. Install O-Ring, 10MB358 into outer O-Ring groove of this bottom ring.
5. Install two (2) pieces of 10MB20 packing into each one of the middle rings, 10MB09B.
6. Install packing into the grease ring, 10MB09C.
7. On a flat surface place the bottom ring, 10MB09A with packing up and install one of the middle rings, 10MB09B with packing up.
8. Install the other middle ring, 10MB09B with packing up.
9. Install the grease ring, 10MB09C with packing up.
10. Install the upper ring, 10MB09D.
11. Install one of the O-Rings, 10MB347 into the O-Ring groove in top upper ring, 10MB09D.
12. Slide the packing box, 15MB03 on this assembly.
13. Place the upper packing flange onto the top of the packing box.
14. Install the last piece of packing, 10MB20 into the bottom ring 10MB09E.
15. Install the upper lock ring, 10MB09E onto this bottom ring.
16. Install this assembly (bottom ring, packing and upper lock ring) onto the short side of the washpipe. Note: Check to make sure the extensions of the upper lock ring slip onto the flats provided on the washpipe, 10MB25.
17. Slide the washpipe with this assembly into the upper packing flange and through the assembled packing box.
18. Turn completed packing assembly on its side and install the O-Ring, 10MB347 into the O-Ring groove of the upper bottom ring and wire the packing assembly together. Store for future use.

Note: All other services not included in the above are considered major repairs and should be done by an authorized service center.

Swivel Size (in inches)	A	B	C	D	E	F	G	H
10MB*	69 1/2	35	4 1/4	17 1/2	16 7/8	20	14	2 1/2
15MB	64 7/8	48 3/4	5	20 1/16	9 3/4	26	16 1/2	3 1/2
25MB	93	54 3/4	5 3/4	24 1/4	17 1/4	30 1/2	20 1/2	4
35MB	97 5/16	54 5/16	6 3/4	24	17 1/2	35	23 1/2	5

*10MB has bottom pin connection.